

2010 Mustang GT500 Connections

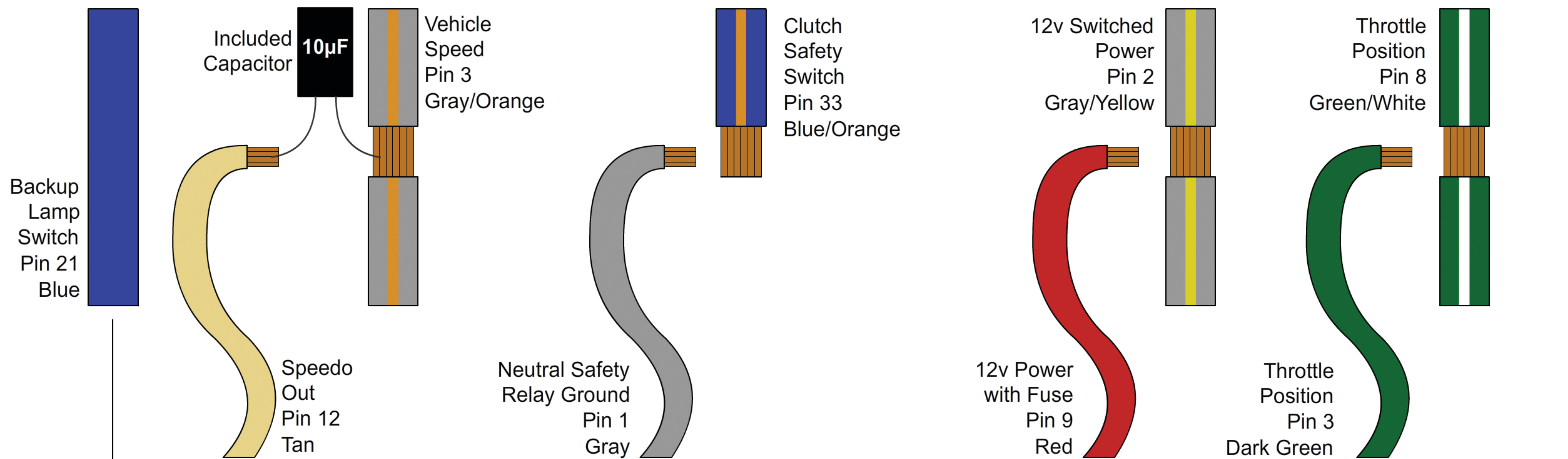
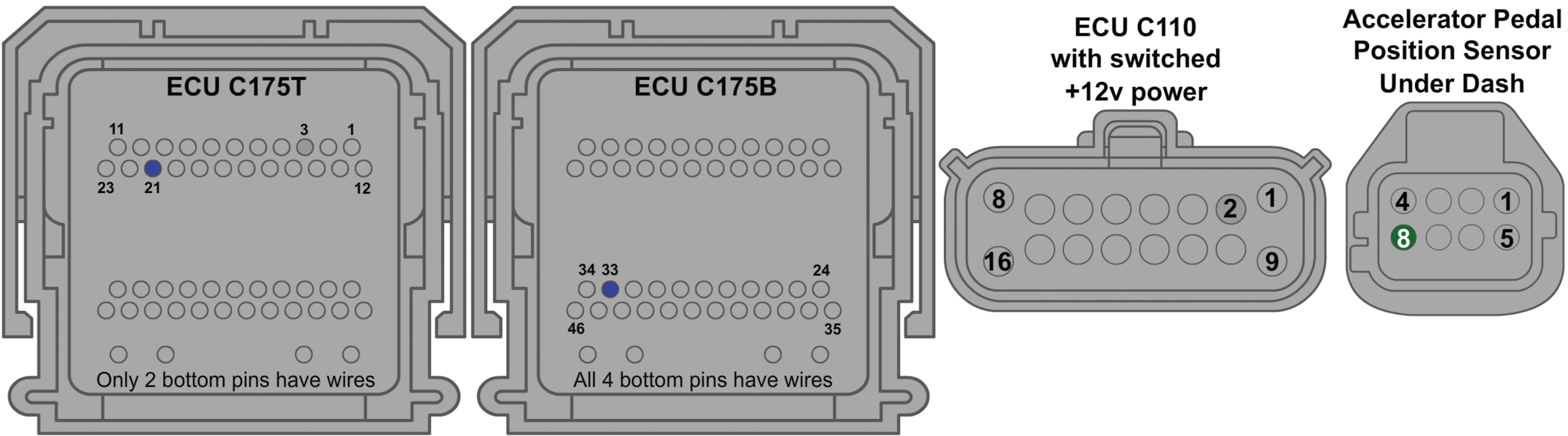

Connect according to the accompanying diagram

16 ● Black	15 ● Black	14	13	12 ● Tan	11	10 ● Pink	9 ● Red
8	7 ● Yellow	6	5	4	3 ● Green	2	1 ● Gray

16-Pin Vehicle Connector

BACK VIEW

(FRONT PLUGS IN, WIRES COME OUT OF THE BACK)

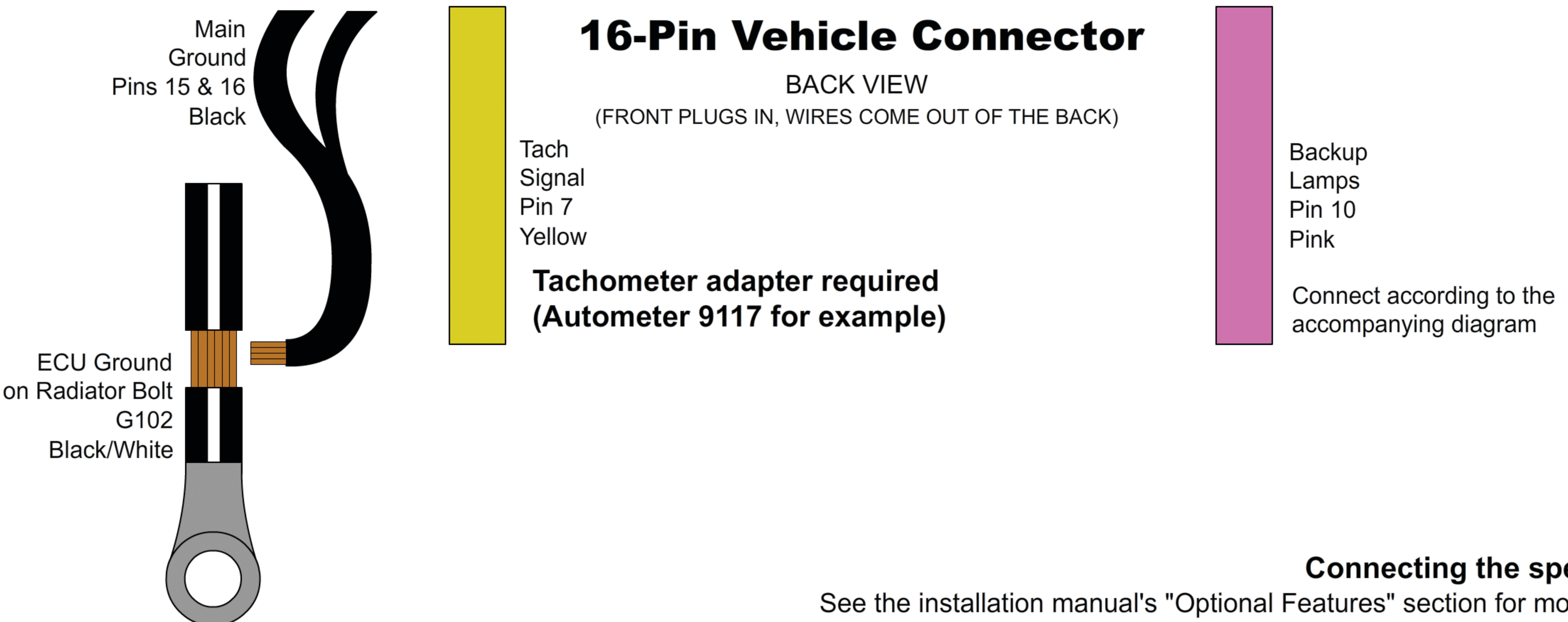

Connecting the speedo out

See the installation manual's "Optional Features" section for more details.

2010 Mustang GT500 Connector Locations

Under Dash
Above Accel Pedal

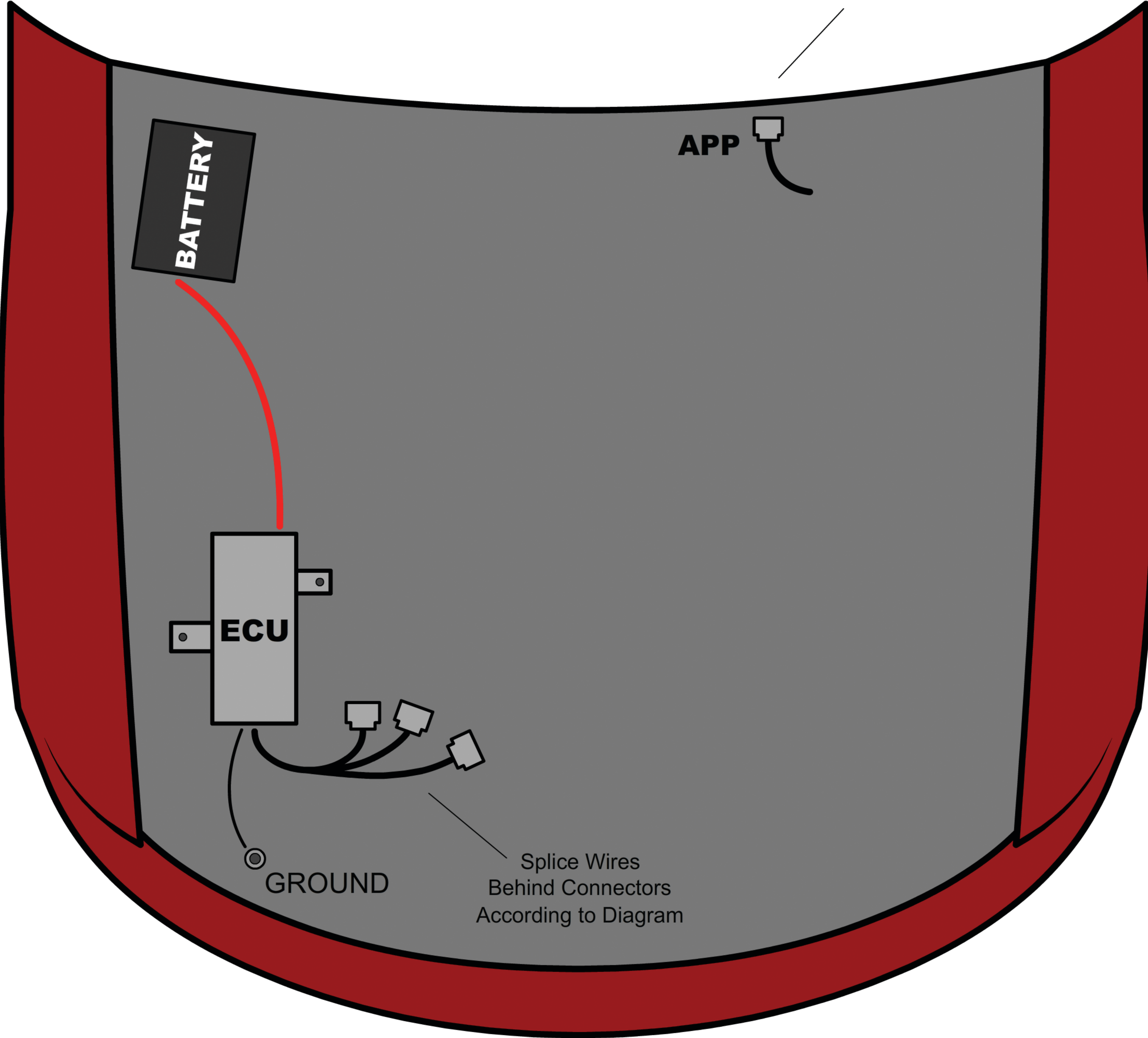

Quick 6 Backup Lamp Relay

for 2010 Mustang GT500

